

Emergency Backup Power Supply

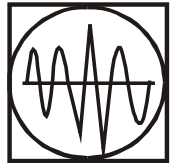

For Use With Computer Loads Only



Power Surge/Noise Protection

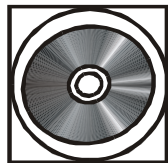

Intelligent Auto-Shutdown Software



Internet Line Protection



Cost Efficiency

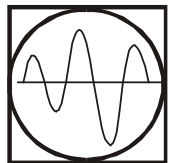

AVR Protection

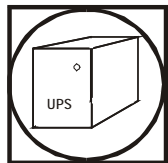

Compact & Reliable Design

USER'S MANUAL



2nd Edition

Uninterruptible Power System

UPS-7700CR-NLCD-02

TROUBLE SHOOTING

If the UPS failed to operate properly, please review the following checks firstly. If the problem remains, please consult sales agent for service.

- Is the Master power switched on?
- Is the UPS plugged into a correctly working outlet?
- Is the line voltage within the rating specified?
- Is the fuse on the rear panel blown?
- Is the UPS over loaded?
- Is battery not fully charged? Dead battery? Charger failure?

Please provide the following information when call for service.

1. Model number, serial number.
2. Date of the problem occurred, date of purchase.
3. Full description of the problem including load, LCD, and alarm status, installation condition, working environment, etc.

Trouble-Shooting Chart		
Problem	Possible Cause	Caution To Take
UPS can not turn on	Battery voltage less than 10VDC	Recharge the battery
	PCB failure	Replace the PCB, call for service
LCD not light	Load less than 25W at battery mode	Normal: "No load shutdown function " is active
UPS always at battery mode	Power cord lose	Plug in the power cord
	AC fuse burn out	Replace the AC fuse
	PCB failure	Replace the PCB, call for service
Back up time too short	Battery not fully charged	Recharge the UPS at least 5 hours
	Battery defective	Recharging the Battery; Call for service
Buzzer continuous beeping	Overload	Remove some loads

IMPORTANT SAFETY INSTRUCTIONS

Thank you for selecting this uninterruptible power system (UPS). It provides you with better protection for connected equipment.

Please read this manual !

This manual provides safety, installation and operating instructions than will help you derive the fullest performance and service life that the UPS has to offer.

Please save this manual !

It includes important instructions for the safe use of this UPS and for obtaining factory service should the proper operation of the UPS come into question.

Please save or recycle the packaging materials !

The UPS's shipping materials were designing with great care to provide protection from transportation related damage. There materials are invaluable if you ever have to return the UPS for service. Damage sustained during transit is not covered under the warranty.

CONTENTS

	PAGE
1. CAUTION.....	1
2. INTRODUCTION	
SYSTEM DESCRIPTION.....	2
FEATURES.....	2
3. SYSTEM CONCEPT	
BLOCK DIAGRAM.....	3
NORMAL OPERATION.....	3
AC UTILITY FAILURE.....	4
4. OVERVIEW	
FRONT PANEL.....	5
REAL PANEL.....	6
5. INSTALLATION AND OPERATION.....	7
6. BATTERY FACTS.....	8
7. SPECIFICATIONS.....	9
8. TROUBLE SHOOTING.....	10

SPECIFICATIONS

Capacity	VA	1000VA	2000VA
Input	Voltage	110VAC, 115VAC, 120VAC, 220VAC, 230VAC or 240VAC -30%, +25%	
	Frequency	50Hz or 60Hz (Auto-sensing)	
Output	Voltage (Batt. Mode)	110VAC, 115VAC, 120VAC, 220VAC, 230VAC or 240VAC ±10%	
	Frequency	AC mode: 47-53Hz for 50Hz or 57-63Hz for 60Hz ; Battery mode:50Hz or 60Hz +/- 1Hz	
	Waveform	Modified sine wave	
	Transfer Time	Less than 6ms (typical)	
Battery	Battery Type	12V/7AH *2PCS	12V/9AH *2PCS
	Recharge Time	5 hours to 90% of full capacity	
Indicator	LCD	I/P & O/P Voltage & Frequency, Load %, Battery %, Battery Fail, Normal, Overload, Fault	
Alarm	Battery Back-up	Two short tones every 8 seconds	
	Battery Low	Four short tones every second	
	Overload	Beeping continuously	
	Fault	Beeping continuously	
Protection	Overload	Yes	
	Short Circuit	AC Fuse and Electronics Circuit (Line mode) ; Electronics Circuit (Back-up mode)	
	Batt. Low Cut-off	No battery drain after cut-off	
Physical	Dimension, D*W*H	337 mm*19**2U	
Environment	Operating Temperature	32°F-104°F at full load, 0~90% relative humidity (non-condensing)	
	Noise Level	Less than 40db (at 1 meter)	
Interface	Contact Closure	USB port	

BATTERY FACTS

The battery is the only periodically serviceable parts in the UPS. An expected life is approx. 3~5 years. However, frequent long discharges or ambient temperatures above 80°F will shorten battery life. Therefore, it is recommended to replace the batteries every 3 years after initiating the unit.

Recharge batteries every 3 months is necessary if it is not in use because it may cause batteries over-drain.

WARNING

Only a qualified technician should replace the battery. Batteries have high short-circuit current capacity; mistakes in connecting or disconnecting can cause connections to arc or weld and could cause severe burns.

STORAGE

The UPS should only be stored if the battery is fully charged. Avoid storage temperatures above 80°F as battery life is significantly shortened. Every 90 days remove the unit from storage and plug it in for 24 hours to recharge the batteries. Batteries may be damaged if left in storage and not recharge every 90 days.

IMPORTANT NOTICE

Please use same type and same rating of batteries for replacement.

Do not replace it with the battery that exceeds specified rating.

CAUTION

- The UPS contains voltages that are potentially hazardous. All repairs should be performed by qualified service personal.
- The UPS has its own internal energy source (battery). The output receptacles may be alive even when the UPS is not connected to an AC supply.
- The UPS is suitable for computers and electronic equipment with substantially rectifier or capacitive loads, not suitable for electronic equipment with significant inductive loads, such as motors & fluorescent lamps.
- Be sure to operate within the power rating of the UPS. Below 1/2 or 1/3 of rated power is recommended for longer backup time & longer battery life.
- Do not place the UPS near excessive humidity, under sunshine, or close to heat-emitting sources.
- If the UPS is out of order, please detach power cord and consult your dealer right away. Do not remove cover if there is no serviceable part inside.
- The unit should be supplied by grounded source. Do not operate the unit without ground source.
- The socket-outlet should be installed near the equipment and be easily accessible.
- Do not plug the UPS power cord into itself. That will result in a safety hazard.
- Installation should be performed by a qualified technician or electrician in accordance with local electrical codes.

INTRODUCTION

System Description

The product is line interactive UPS with LCD display, the newest technology and powerful function. The Line Interactive UPS is designed with 2- steps Boost and 1-step Buck AVR to stabilize input voltage. Input voltage range is -30%, +25% but output regulation is +/-10%.

The Line Interactive UPS provides you with the ability of perfect protection of your critical devices.

Features

- Controlled by a technologically advanced microprocessor guaranteeing high reliability
- Rack / tower convertible design.
- Equipped with 2-steps boost & 1-step buck AVR to stabilize output voltage
- Provides lightning, surge, overload, and short-circuit protection.
- Constant current, constant voltage battery charger (CCCV Battery Charger).
- UPS will shut down upon battery low ; UPS will restart automatically upon AC recovery (Auto-restart).
- Built-in DC start function enables UPS to be started without AC power supplied
- Tel / Modem / Fax / Internet surge suppression.
- Management software is designed to monitor and control UPS status.
- Built-in DC start function enables UPS to be started without AC power supplied

INSTALLATION AND OPERATION

Upon receipt of the UPS, inspect the shipping carton for damage. If there is any obvious damage, immediately report it to the selling dealer or the delivering carrier. If there is no damage to the shipping carton, unpack the unit and inspect the unit for damage.

The UPS is designed for installation in a protected environment within a temperature range from 32°F to 104°F and relative humidity of 0~90% without condensation. Do not block inlets and outlets. Install the system in a location free from excessive dust and chemical fumes.

Check the identification label to verify the UPS voltage and power rating match the available line voltage and load requirements.

Operation:

1. When UPS is connected to city utility, but UPS is not powered on, UPS will charge battery automatically and LCD display will show "UPS off".
2. To turn on the UPS unit, press the power On/Off Switch once. To turn off the UPS unit, press the power On/Off Switch again.
3. DC Start.
When the UPS is off and there is no power utility, it's still possible to cold start the UPS unit to power the loads
4. When UPS is under battery mode and battery voltage is too high or low, buzzer will beep.
5. Buzzer will beep twice every 8 seconds when city utility is black out.

Rear Panel

European socket type:

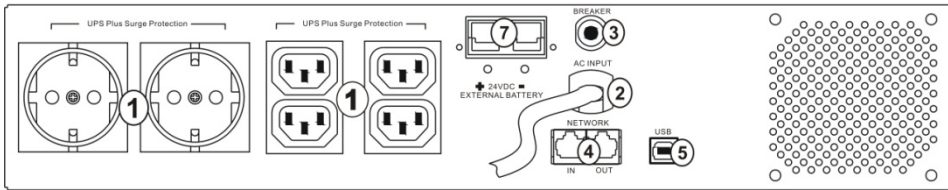
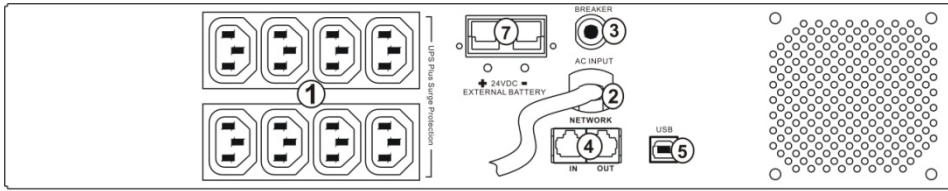

Nema 5-15R socket:

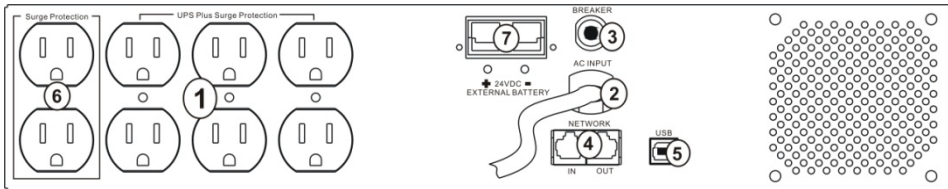

1. **Outlets**
2. **AC Input**
3. **AC breaker**
4. **Tel / Modem Spike Protection Port:** Telecom transfer ports provide users to extend the applications.
5. **Communication Interface Port:** USB port.
6. **Surge Protection Only**
7. **External Battery Connector (Optional)**

SYSTEM CONCEPT

The purpose to present this chapter is to give you more precise conception about how UPS works..

1. Block Diagram

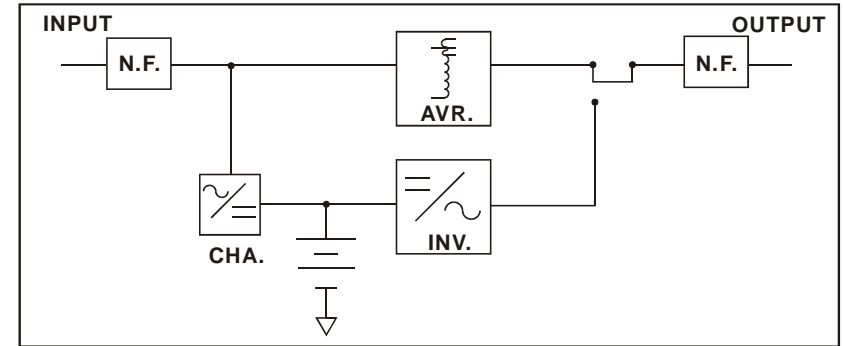

Fig. 1 shows how UPS works.

2. Normal Operation

There are two main loops when AC Utility normal the AC output loop and the battery charging loop. The AC output gets power from AC utility input and pass through AVR to support power to load. In the same time, the AC utility input is converted by AC/DC CHA and support charging power to charge batteries.

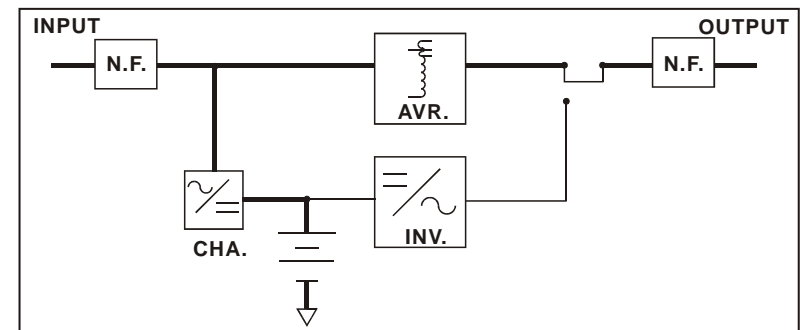

Fig. 2 shows how the UPS works when AC Utility normal.

3. AC Utility Failure

If AC utility fails, the UPS quickly detects the problem and activates the inverter. The DC/AC inverter changes DC power from the batteries into AC and provides continuous uninterruptible power to load.

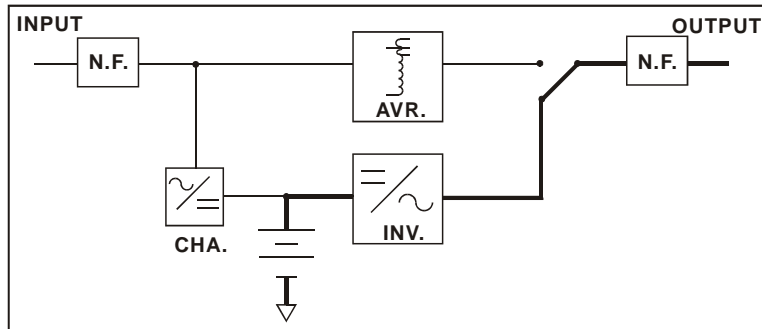
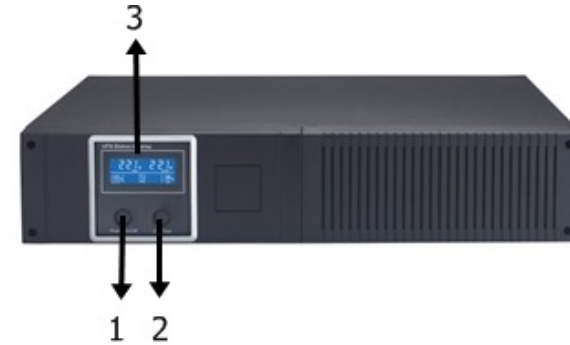

Fig. 3 shows how the UPS works when AC Utility Failure

OVERVIEW

Front Panel



1. **Master Power Switch:** Turn on / off the UPS.
2. **UPS test Switch:** When UPS is working on AC mode, it also activates the UPS's self-test by press this button.
3. **LCD display**

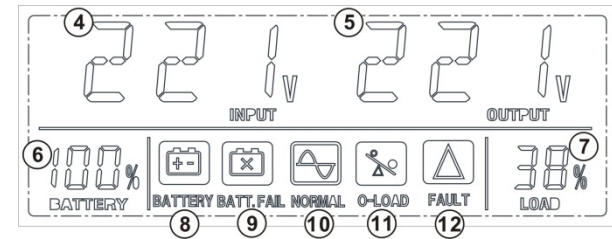

No.	Indication	Description
4	Input Voltage	Indicate input line voltage value. Input voltage will blink continuously in back up mode
5	Output Voltage	Indicate output voltage value.
6	Battery Capacity	Estimated battery capacity, the accuracy is influenced by UPS operation mode and load level.
7	Load Level	The load level, percentage of full load.
8	Battery	AC power is abnormal and UPS is on back-up mode.
9	Battery Fail	UPS battery is in abnormal. Please check or replace the battery.
10	Normal	UPS is under normal status.
11	Overload	UPS is overloaded. Buzzer will beep continuously. Please remove some load.
12	Fault	UPS is in fault condition and alarm will beep continuously.

