

Media Converter Chassis System

User's Guide

FCC Warning

This equipment has been tested and found to comply with the regulations for a Class A digital device, pursuant to Part 15 of the FCC Rules. These limits are designed to provide reasonable protection against harmful interference when the equipment is operated in a commercial environment. This equipment generates, uses, and can radiate radio frequency energy and, if not installed and used in accordance with this user's guide, may cause harmful interference to radio communications. Operation of this equipment in a residential area is likely to cause harmful interference, in which case the user will be required to correct the interference at his or her own expense.

CE Mark Warning

This is a Class A product. In a domestic environment, this product may cause radio interference, in which case the user may be required to take adequate measures.

VCCI Warning

This is a product of VCCI Class A Compliance.

注意

この装置は、情報処理装置等電波障害自主規制協議会(VCCI)の基準に基づく第一種情報技術装置です。この装置を家庭環境で使用すると電波妨害を引き起こすことがあります。この場合には使用者が適切な対策を講ずるよう要求されることがあります。



TABLE OF CONTENTS

PREFACE	1
19" MEDIA CONVERTER CHASSIS SYSTEM	2
PRODUCT FEATURES	3
PRODUCT FEATURES	3
UNPACKING AND INSTALLATION	5
UNPACKING	5
INSTALLATION	5
DECIDING HOW TO INSTALL THE SYSTEM.....	6
. <i>Mounted to 19-inch standard rack</i>	6
. <i>Installing Media Converter</i>	6
. <i>Connecting to Power (Power Supply)</i>	7
. <i>Installing and Removing the Power Supply</i>	8
UNDERSTANDING LED INDICATORS	9
FRONT PANEL	9
POWER AND FAN LED	9
TECHNICAL SPECIFICATIONS	10
ORDERING INFORMATION	12
100TX ~ 100FX MEDIA CONVERTER	12
10/100TX ~ 100FX MEDIA CONVERTER	13
1000T ~ 1000SX/LX MEDIA CONVERTER.....	14
100FX ~ 100FX MEDIA CONVERTER	15
1000SX/LX ~ 1000LX MEDIA CONVERTER.....	16
POWER SUPPLY	17
CPU MODULE.....	17

PREFACE

This manual describes how to install and use the 19” Media Converter Chassis System. The system introduced here is capable of housing up to sixteen media converters, each of which offers one channel media conversion solution:

- ◆ 100BASE-TX ↔ 100BASE-FX
- ◆ 10/100BASE-TX ↔ 100BASE-FX
- ◆ 100BASE-FX ↔ 100BASE-FX (multi-mode ↔ single-mode)
- ◆ 1000BASE-T ↔ 1000BASE-SX/LX
- ◆ 1000BASE-SX ↔ 1000BASE-LX (multi-mode ↔ single-mode)

In this manual, you will find:

- ◆ Introduction on the Chassis System
- ◆ Product features
- ◆ Illustrative LEDs functions
- ◆ Installation instructions
- ◆ Specifications
- ◆ Ordering Information

Attention!

Shown in the figures of this manual is fitted with redundant power supplies. Proprietary media converters and a second power supply shall be ordered separately!

19" Media Converter Chassis System

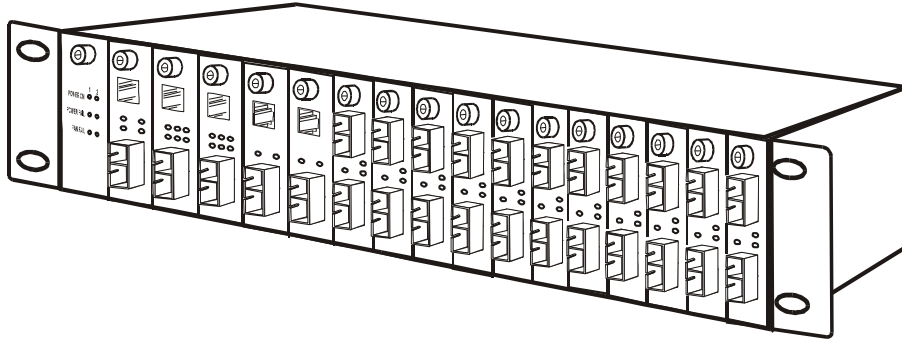

The chassis equipped with two power supplies and sixteen media converters.

Attention!

The chassis system ships with only one power supply.

Proprietary media converters and a second power supply are not included!

PRODUCT FEATURES

This chapter describes the features of the Media Converter Chassis System.

Product Features

- Plug-and-Play
- House up to Sixteen media converters
- Front panel LEDs for bay and fan power status
- Standard 19” rackmountable size, 2U
- Non-stop operation & minimal downtime
- The following items are designed to be hot swappable to allow easy and quick replacement:
 - Media converters
 - Redundant Power supplies
- Provides cooling fans at the back together with power supply
- Power redundancy & power isolation
- One high quality internal power supply provided, and a second power supply option for load-sharing purpose.
- Load sharing mechanism: If one power supply should fail, the redundant power supply is capable of taking over immediately
- The Media Converter’s power isolation ensures each bay is electrically isolated from each other

UNPACKING AND INSTALLATION

This chapter provides unpacking and installation information for the Switch. To avoid causing any damage to the Switch, we recommend that you read this chapter carefully before starting installation.

Unpacking

When unpacking the product package, you shall find these items listed below.

- **19” Media Converter Chassis System**
- **One power supply installed on the chassis**
- **One AC power cord**
- **User’s Manual**
- **Accessories: rackmount screws (8 pcs) & rackmount ears (2 pcs) rubber foot (4 pcs)**

If any item is found missing or damaged, please contact your local reseller for replacement.

Installation

The site where you place the chassis system may greatly affect its performance. When installing, take the following into your consideration:

As with any electric device, you should place the equipment where it will not be subjected to extreme temperatures, humidity, or electromagnetic interference. Specifically, the site you select should meet the following requirements:

- ◆ The ambient temperature should be between 32 and 104 degrees Fahrenheit (0 to 40 degrees Celsius).
- ◆ The relative humidity should be less than 90 percent, non-condensing.
- ◆ Surrounding electrical devices should not exceed the electromagnetic field (RFC) standards for IEC 801-3, Level 2 (3V/M) field strength.
- ◆ Make sure that the equipment receives adequate ventilation at the rear. Do not block the fan exhaust holes on the rear of the chassis.

The power outlet should be within 1.8 meters of the chassis.

Deciding How to Install the System

We strongly suggest that you install the chassis first, as this is more convenient for you to install media converters into the chassis with ease. The accessories supplied in the product package includes: rackmount screws(8 pcs) and rackmount brackets(2 pcs). This well-built chassis can be installed in the following ways:

.Mounted to 19-inch standard rack

Use the rackmount brackets and screws to install the chassis into any EIA 19” standard rack.

Step 1: Attach the brackets to each side of the chassis. Apply four screws to each side and secure them tightly.

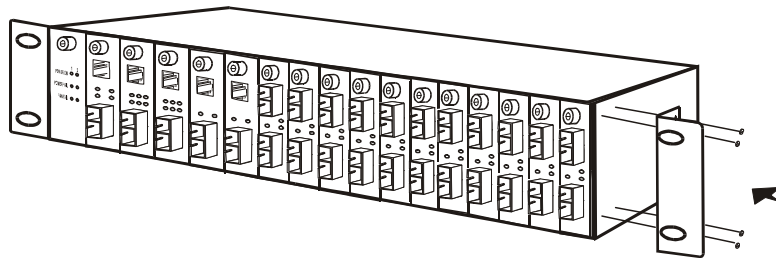

Step 2: Carefully position the chassis into the rack. Align the brackets to the side holes on the rack and use rack screws to secure the chassis with the rack.

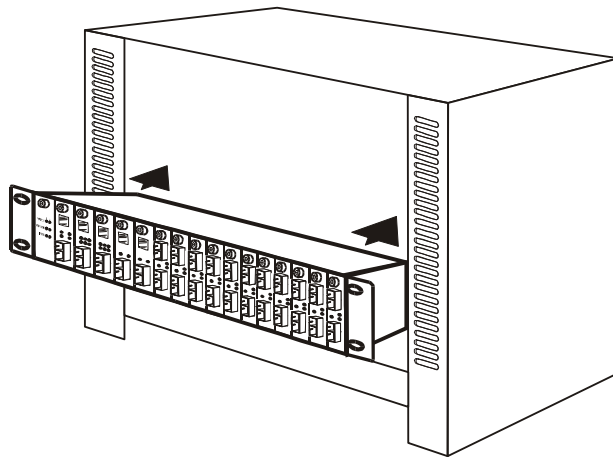

Step 3: Proceed to the “Connecting to Power” section.

.Installing Media Converter

The chassis is equipped with sixteen media converter carriers, each of which is fitted into bays of the chassis.

Step 1: To install a media converter module onto the chassis, you have to unscrew the bay cover from the desired bay first.

Step 2: Unscrew the hand screw counter clockwise by using hand or screwdriver and pull out the media converter out the carrier as shown below.

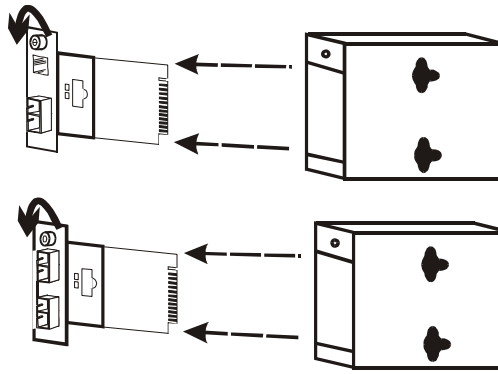

Unscrew the hand screw counter clockwise by using hand or screwdriver and pull the media converter module out on the carrier

Step 3: Carefully slide in the module and fasten the hand screw clockwise by using hand or screwdriver until it is fully and firmly fitted into the slot of the chassis.

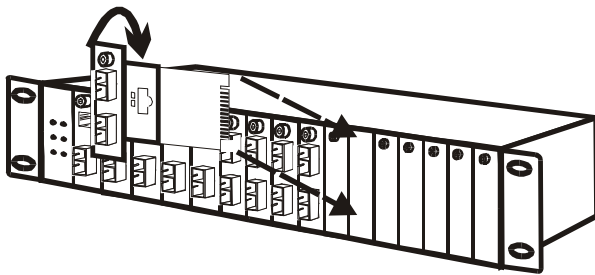

Insert the media converter module into an available slot and fasten the hand screw clockwise by using hand or screwdriver.

• *Connecting to Power (Power Supply)*

The chassis ships with only one power supply, and a second power supply option is at your discretion. When the chassis is equipped with two power supplies, you can have the following advanced performance.

◆ **Hot Swappable –**

The design of the power system is based on an idea of providing maximum flexibility and redundancy. In this way, you may remove any of the two power supplies without turning off the system.

◆ **Redundancy –**

During operation, both power supplies are switched on and share the current load. In case that one of them should fail, the other will instantaneously take 100% of the load without any loss. Similarly, if one power supply is removed from servicing, it can be switched off and removed while the chassis continues functioning.

◆ Protection System –

The power of each converter bay comes from the two shared power supplies. Each bay is isolated from each other under a certain protection mechanism, so that it is free from any problem that might occur to the power supplies or faulty converter bay. This is the best solution to protect your investment in media converters.

Attention!

There is an optional solution for the backup power, -48 volt DC to DC Power Supply.

The chassis system is equipped with one power supply and allows one additional power supply for redundancy. For reliable operation, we suggest that you run the chassis system with two power supplies are in place.

Step 1: Connect the supplied AC power cord to the back of the chassis.

Step 2: Attach the plug into a standard AC outlet with a voltage range from 100~240Vac.

Step 3: Turn on the chassis system by flipping the switch beside the receptacle to ON position. The LED on the front panel of power supply will come on then.

• *Installing and Removing the Power Supply*

- To remove a power supply out the chassis, you have to loose the hand screw counter clockwise and pull out the power supply from the chassis.
- To install a power supply to the chassis, you have to fasten the hand screw clockwise and slide in the power supply to the chassis.

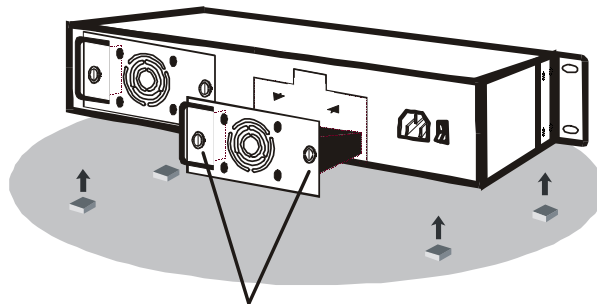

You can slide in and out the power supply from the bay, fasten or loose the hand screw clockwise or counter clockwise by using hand or screwdriver.

Attention!

If the Chassis System needs to work alone, you can stick up four Rubber foot below the chassis!

UNDERSTANDING LED INDICATORS

The front panel LEDs provide instant status feedback, and, helps monitor and troubleshoot when needed.

Front Panel

There is an array of LED indicators, which provides you with instant feedback on the status of the power and the fan.

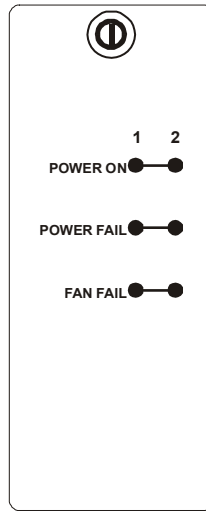

Power and Fan LED

1 / 2	Indicates which the power (fan) is working, depends on where the power supply was installed at the rear.	
Power LED	On (Green)	Power supply feed in
	Off	No power supply feeding
Power Fail LED	On (Amber)	Faulty power supply
	Off	Power supply works normally
Fan Fail LED	On (Amber)	Faulty Fan
	Off	Fan works normally

TECHNICAL SPECIFICATIONS

Chassis System	
Capacity	Sixteen bays for housing up to sixteen media converters
Material	Steel
Power	One power supply provided, hot-swappable *A second power supply for load-sharing is optional, also hot-swappable
Cooling	Two fans mounted together with the power supply or alone at the rear
LED Indicators	2 LEDs for fan status 2 LEDs for power feeding in status 2 LEDs for power supply's power status
Dimensions	W440 mm × D 360 mm × H88 mm (D395 mm including power supply unit) Standard 19" size, 2 U
Net Weight	7.0kg approx. (*Only one power supply included)

Fan	
Rated Voltage	12Vdc
Speed	3200 RPM +/- 250 RPM
Air Delivery	42.5 CFM per min.
Noise Level	36.5dB(A)
Bearing System	Precise ball bearing system
Dimensions	80 × 80 × 25 mm

Power Supply	
AC inputs:	100 to 240 VAC, universal power supply
Power Consumption:	150 watts. (max.)
Temperature	Operating: 0°~40° C, Storage: -10°~50° C
Humidity	Operating: 10% ~ 90%, Storage: 5% ~ 90%
Overload Protection	All outputs protected from short circuit condition, automatic recovery
Emissions:	FCC Class A, CE Mark Class A, VCCI Class A

ORDERING INFORMATION

100TX ~ 100FX Media Converter

Port One			Port Two		
Speed	Cable / Connector	Distance	Speed	Cable (/125µm) Connector	Distance
100TX	2-pairs Cat. 5 RJ-45	100m	100FX	MMF (50µm or 62.5µm) SC	2km
100TX	2-pairs Cat. 5 RJ-45	100m	100FX	MMF (50µm or 62.5µm) ST	2km
100TX	2-pairs Cat. 5 RJ-45	100m	100FX	MMF (50µm or 62.5µm) MT-RJ	2km
100TX	2-pairs Cat. 5 RJ-45	100m	100FX	MMF (50µm or 62.5µm) LC	2km
100TX	2-pairs Cat. 5 RJ-45	100m	100FX	SMF (9µm or 10µm) SC	15km
100TX	2-pairs Cat. 5 RJ-45	100m	100FX	SMF (9µm or 10µm) SC	30km
100TX	2-pairs Cat. 5 RJ-45	100m	100FX	SMF (9µm or 10µm) SC	40km
100TX	2-pairs Cat. 5 RJ-45	100m	100FX	SMF (9µm or 10µm) SC	60km

10/100TX ~ 100FX Media Converter

Port One			Port Two		
Speed	Cable / Connector	Distance	Speed	Cable (/125μm) Connector	Distance
10/100TX	2-pairs Cat. 5 RJ-45	100m	100FX	MMF (50μm or 62.5μm) SC	2km
10/100TX	2-pairs Cat. 5 RJ-45	100m	100FX	MMF (50μm or 62.5μm) ST	2km
10/100TX	2-pairs Cat. 5 RJ-45	100m	100FX	MMF (50μm or 62.5μm) MT-RJ	2km
10/100TX	2-pairs Cat. 5 RJ-45	100m	100FX	MMF (50μm or 62.5μm) LC	2km
10/100TX	2-pairs Cat. 5 RJ-45	100m	100FX	SMF (9μm or 10μm) SC	15km
10/100TX	2-pairs Cat. 5 RJ-45	100m	100FX	SMF (9μm or 10μm) SC	30km
10/100TX	2-pairs Cat. 5 RJ-45	100m	100FX	SMF (9μm or 10μm) SC	40km
10/100TX	2-pairs Cat. 5 RJ-45	100m	100FX	SMF (9μm or 10μm) SC	60km

1000T ~ 1000SX/LX Media Converter

Port One			Port Two		
Speed	Cable / Connector	Distance	Speed	Cable (/125µm) Connector	Distance
1000T	4-pairs Cat. 5 RJ-45	100m	1000SX	MMF of 850nm (50µm) SC	550m
1000T	4-pairs Cat. 5 RJ-45	100m	1000SX	MMF of 850nm (62.5µm) SC	220m
1000T	4-pairs Cat. 5 RJ-45	100m	1000LX	SMF (9µm or 10µm) SC	10km
1000T	4-pairs Cat. 5 RJ-45	100m	1000LX	SMF (9µm or 10µm) SC	20km

100FX ~ 100FX Media Converter

Port One			Port Two		
Speed	Cable / Connector	Distance	Speed	Cable (/125μm) Connector	Distance
100FX	MMF (50μm or 62.5μm) SC	2km	100FX	SMF (9μm or 10μm) SC	15km
100FX	MMF (50μm or 62.5μm) SC	2km	100FX	SMF (9μm or 10μm) SC	40km
100FX	MMF (50μm or 62.5μm) SC	2km	100FX	SMF (9μm or 10μm) SC	30km
100FX	MMF (50μm or 62.5μm) SC	2km	100FX	SMF (9μm or 10μm) SC	60km

1000SX/LX ~ 1000LX Media Converter

Port One			Port Two		
Speed	Cable / Connector	Distance	Speed	Cable (/125μm) Connector	Distance
1000SX	MMF of 850nm (50μm) SC	550m	1000LX	SMF (9μm or 10μm) SC	10km
1000SX	MMF of 850nm (62.5μm) SC	220m	1000LX	SMF (9μm or 10μm) SC	10km
1000SX	MMF of 850nm (50μm) SC	550m	1000LX	SMF (9μm or 10μm) SC	20km
1000SX	MMF of 850nm (62.5μm) SC	220m	1000LX	SMF (9μm or 10μm) SC	20km
1000LX	SMF (9μm or 10μm) SC	20km	1000LX	SMF (9μm or 10μm) SC	20km

Power Supply

Power Type
150 Watt AC to DC Power Supply
-48 Volt DC to DC Power Supply

CPU Module

Manageable for the Chassis System using console port.
--