

GEL2P-ESW10G

Installation and Getting Started Guide

GEL2P-ESW10G

Installation and Getting Started Guide

10-Port L2 Plus Managed Switch

ABOUT THIS GUIDE

PURPOSE

This guide gives specific information on how to operate and use the management functions of the switch.

AUDIENCE

The guide is intended for use by network administrators who are responsible for operating and maintaining network equipment; consequently, it assumes a basic working knowledge of general switch functions, the Internet Protocol (IP), and Simple Network Management Protocol (SNMP).

CONVENTIONS

The following conventions are used throughout this guide to show information:

WARRANTY

See the Customer Support/ Warranty booklet included with the product.

A copy of the specific warranty terms applicable to your Manufacture products and replacement parts can be obtained from your Manufacture Sales and Service Office pr authorized dealer.



NOTE: Emphasizes important information or calls your attention to related features or instructions.



WARNING: Alerts you to a potential hazard that could cause personal injury.



CAUTION: Alerts you to a potential hazard that could cause loss of data, or damage the system or equipment.

COMPLIANCES AND SAFETY STATEMENTS

FCC-CLASS A

This equipment has been tested and found to comply with the limits for a Class A computing device pursuant to Subpart J of part 15 of FCC Rules, which are designed to provide reasonable protection against such interference when operated in a commercial environment.

This equipment generates, uses, and can radiate radio frequency energy and, if not installed and used in accordance with the instruction manual, may cause harmful interference to radio communications. Operation of this equipment in a residential area is likely to cause harmful interference in which case the user will be required to correct the interference at his own expense.

You are cautioned that changes or modifications not expressly approved by the party responsible for compliance could void your authority to operate the equipment.

You may use unshielded twisted-pair (UTP) for RJ-45 connections – Category 3 or better for 10 Mbps connections, Category 5 or better for 100 Mbps connections, Category 5, 5e, or 6 for 1000 Mbps connections. For fiber optic connections, you may use 50/125 or 62.5/125 micron multimode fiber or 9/125 micron single-mode fiber.

CE MARK DECLARATION OF CONFORMANCE FOR EMI AND SAFETY (EEC)

This equipment has been tested and found to comply with the protection requirements of European Emission Standard EN55022/EN61000-3 and the Generic European Immunity Standard EN55024.

EMC:

EN55022(2006)+A1:2007/CISPR 22:2006+A1:2006	Class A 4K V CD, 8KV, AD
IEC61000-4-2 (2001)	3V/m
IEC61000-4-3(2002)	1KV – (power line), 0.5KV – (signal line)
IEC61000-4-4(2004)	Line to Line: 1KV, Line to Earth: 2KV
IEC61000-4-5 (2001)	130dBuV(3V) Level 2
IEC61000-4-6 (2003)	1A/m
IEC61000-4-8 (2001)	Voltage dips: >95%, 0.5period, 30%, 25periods
IEC61000-4-11(2001)	Voltage interruptions: >95%, 250periods



CAUTION: Circuit devices are sensitive to static electricity, which can damage their delicate electronics. Dry weather conditions or walking across a carpeted floor may cause you to acquire a static electrical charge.

To protect your device, always:

- Touch the metal chassis of your computer to ground the static electrical charge before you pick up the circuit device.
- Pick up the device by holding it on the left and right edges only.
- If you need using outdoor device connect to this device with cable then you need to addition an arrester on the cable between outdoor device and this device.

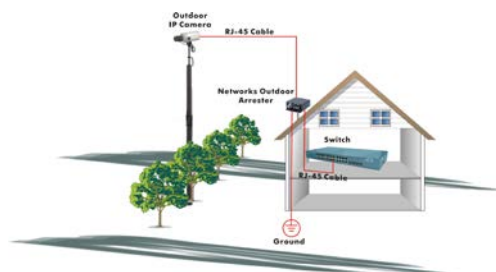

Fig. Addition an arrester between outdoor device and this switch

- The switch supports the SFP Vendor includes: Manufacture, Agilent, Avago and Finisa



NOTE: The switch is indoor device; if it will be used in outdoor environment or connects with some outdoor device, then it must use a lightning arrester to protect the switch



WARNING:

- Self-demolition on Product is strictly prohibited. Damage caused by self-demolition will be charged for repairing fees.
 - Do not place product at outdoor or sandstorm.
 - Before installation, please make sure input power supply and product specifications are compatible to each other.
 - To reduce the risk of electric shock. Disconnect all AC or DC power cord and RPS cables to completely remove power from the unit.
 - Before importing / exporting configuration please make sure the firmware version is always the same.
 - After firmware upgrade, the switch will remove the configuration automatically to latest firmware version.
-

RELATED PUBLICATIONS

The following publication gives specific information on how to operate and use the management functions of the switch:

The User's Manual

REVISION HISTORY

This section summarizes the changes in each revision of this guide.

Release	Date	Revision
6.38	10/19/2015	A1

Contents

ABOUT THIS GUIDE	ii
COMPLIANCES AND SAFETY STATEMENTS	iii
INTRODUCTION	1
OVERVIEW	1
DESCRIPTION OF HARDWARE	4
NETWORK PLANNING	6
INTRODUCTION TO SWITCHING	6
APPLICATION EXAMPLES	6
INSTALLING THE SWITCH.....	7
SELECTING A SITE	7
ETHERNET CABLING	7
EQUIPMENT CHECKLIST	8
PACKAGE CONTENTS	8
MOUNTING.....	8
INSTALLING AN OPTIONAL SFP TRANSCEIVER.....	11
CONNECTING TO A POWER SOURCE	13
CONNECTING TO THE CONSOLE PORT.....	13
Operation of Web-based Management.....	15
MAKING NETWORK CONNECTIONS.....	15
CONNECTING NETWORK DEVICES	16
TWISTED-PAIR DEVICES	16
FIBER OPTIC SFP DEVICES.....	22
CABLE LABELING AND CONNECTION RECORDS.....	25
TROUBLESHOOTING	26
Basic Troubleshooting Tips.....	26
POWER AND COOLING PROBLEMS.....	28
Installation	28

IN-BAND ACCESS	28
CABLES	29
TWISTED-PAIR CABLE AND PIN ASSIGNMENTS	29
STRAIGHT- THROUGH WIRING	30
1000BASE-T PIN ASSIGNMENTS	31
CABLE TESTING FOR EXISTING CATEGORY 5 CABLE.....	31
FIBER STANDARDS	32
SPECIFICATIONS	33
PHYSICAL CHARACTERISTICS.....	33
SWITCH FEATURES.....	33
MANAGEMENT FEATURES.....	1
STANDARDS.....	1
COMPLIANCES.....	35
COMPLIANCES	36

INTRODUCTION

OVERVIEW

The GEL2P-ESW10G Switch, Manufacture network next generation solutions, is a portfolio of affordable managed switches that provides a reliable infrastructure for your business network. These switches deliver more intelligent features you need to improve the availability of your critical business applications, protect your sensitive information, and optimize your network bandwidth to deliver information and applications more effectively. Easy to set up and use, it provides the ideal combination of affordability and capabilities for entry level Networking includes Small Business or enterprise application and helps you create a more efficient, better-connected workforce.

The GEL2P-ESW10G Switch is broad portfolio of easy-implement managed Ethernet switches. Models include with 10-port of Gigabit Ethernet connectivity, providing ideal flexibility to design suitable network infrastructure for business requirement. However, unlike other entry-level switching solutions that provide advance managed network capabilities only in the costliest models, all the Series Switches support the advanced security management capabilities and network features to support includes data, voice, security, and wireless technologies. Besides, these switches are easy to deploy and configure, providing stable and quality performance network services your business needs

Front of the Switches

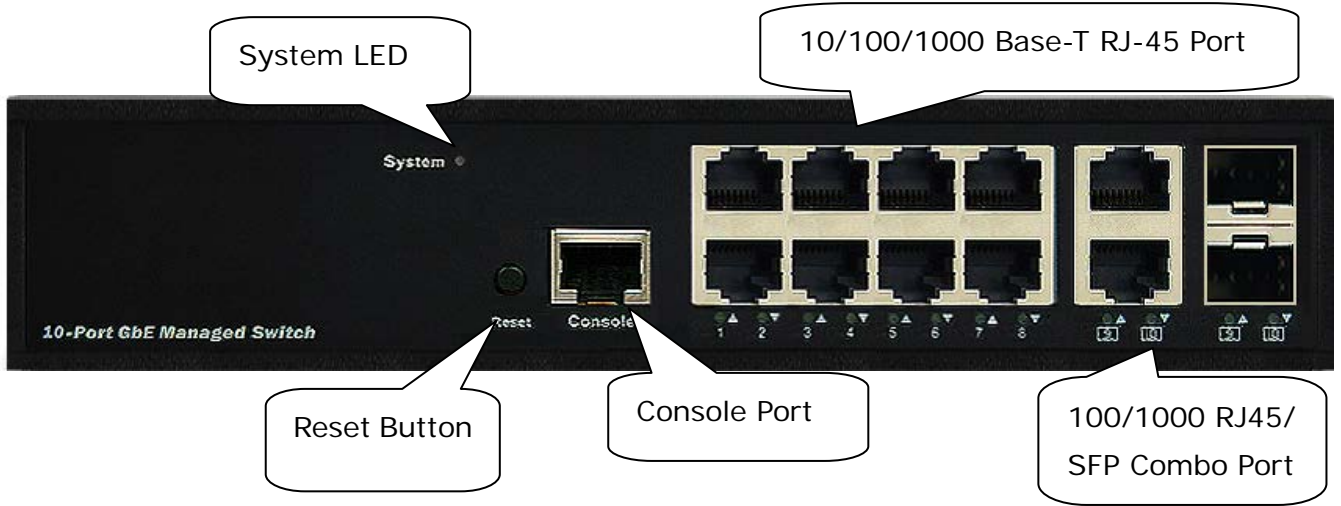

Back of the Switches



SWITCH ARCHITECTURE

The switch performs a wire-speed, non-blocking switching fabric. This allows wire-speed transport of multiple packets at low latency on all ports simultaneously. The switch also features full-duplex capability on all ports, which effectively doubles the bandwidth of each connection.

This switch uses store-and-forward technology to ensure maximum data integrity. With this technology, the entire packet must be received into a buffer and checked for validity before being forwarded. This prevents errors from being propagated throughout the network.

NETWORK MANAGEMENT OPTIONS

The switch can also be managed over the network with a web browser or Telnet application. The switch includes a built-in network management agent that allows it to be managed in-band using SNMP or RMON (Groups 1, 2, 3, 9) protocols. It also has an RJ45 console port connector on the front panel for out-of-band management. A PC may be connected to this port for configuration and monitoring out-of-band via a null-modem serial cable.



NOTE: For a detailed description of the management features, refer to the *User's manual*.

DESCRIPTION OF HARDWARE

1000BASE-T PORTS

The switch contains 10 1000BASE-T RJ-45 ports. All RJ-45 ports support automatic MDI/MDI-X operation, auto-negotiation and IEEE 802.3x auto-negotiation of flow control, so the optimum data rate and transmission can be selected automatically.

SFP TRANSCEIVER SLOTS

GEL2P-ESW10G supports the Small Form Factor Pluggable (SFP) transceiver slots are port 9,10. In the default configuration, if an SFP transceiver (purchased separately) is installed in a slot and has a valid link on the port, the associated RJ-45 port is disabled.

The following table shows a list of transceiver types which have been tested with the switch. For an updated list of vendors supplying these transceivers, contact your local dealer. For information on the recommended standards for fiber optic cabling, see "[1000 Mbps Gigabit Ethernet Collision Domain](#)".

Supported SFP Transceivers

Media Standard	Fiber Diameter (microns)	Wavelength (nm)	Maximum Distance*
1000BASE-SX	50/125	850	550 m
	62.5/125	850	275 m
1000BASE-LX/ LHX/ XD/ZX	9/125	1310	10 km
	9/125	1550	30.50 km
	9/125	1300	10 km
1000BASE-LX Single Fiber	N/A	TX-1310/RX-1550	20 km
		Tx-1550/RX-1310	20 km
1000BASE-T	N/A	N/A	100 m
100-FX	50/125	850	2 km
	62.5/125	1550	15km



NOTE: * Maximum distance may vary for different SFP vendors

**PORT AND
SYSTEM STATUS
LEDS**

The GEL2P-ESW10G switch includes a display panel for system and port indications that simplify installation and network troubleshooting. The LEDs, which are located on left hand side of the front panel for easy viewing. Details are shown below and described in the following tables.

Mode Status LEDs

LED	Condition	Status
Link/ACT/Speed	Green	Lit Green indicates all LED of each port are in Link/ACT/Speed mode.

System Status LED

SYSTEM LED	Condition	Status
Power	Green OFF	Lit when power is coming up

NETWORK PLANNING

INTRODUCTION TO SWITCHING

A network switch allows simultaneous transmission of multiple packets; it can partition a network more efficiently than bridges or routers. Therefore the switch has been recognized as one of the most important devices for today's networking technology.

When performance bottlenecks are caused by congestion at the network access point such as file server, the device can be connected directly to a switched port. And, by using full-duplex mode, the bandwidth of the dedicated segment can be doubled to maximize throughput.

When networks are based on repeater (hub) technology, the distance between end stations is limited by a maximum hop count. However, a switch can subdividing the network into smaller and more manageable segments, and linking them to the larger network than it turns the hop count back to zero and removes the limitation.

A switch can be easily configured in any Ethernet, Fast Ethernet, or Gigabit Ethernet network to significantly increase bandwidth while using conventional cabling and network cards.

APPLICATION EXAMPLES

The GEL2P-ESW10G Switch implements 8 Gigabit Ethernet TP ports with auto MDIX and 2 slots for the removable SFP module (GEL2P-ESW10G port 10) which supports comprehensive types of fiber connection, such as LC and BiDi-LC modules. It is not only designed to segment your network, but also to provide a wide range of options in setting up network connections. Some typical applications are described below.

The switch is suitable for the following applications.

- Remote site application is used in Enterprise or SMB
- Peer-to-peer application is used in two remote offices
- Office network
- High Performance Requirement environment
- Advance Security for network safety application
- Suitable for data/ voice and video conference application

INSTALLING THE SWITCH

SELECTING A SITE

The Switch can be mounted in a standard 19-inch equipment rack (Via **Optional Rack mount Kit**) or on a flat surface. Be sure to follow the guidelines below when choosing a location.

- ◆ The site should:
 - Be at the center of all the devices you want to link and near a power outlet.
 - Be able to maintain its temperature within 0 to 45°C (32 to 113 °F) and its humidity within 10% to 90%, non-condensing.
 - Be accessible for installing, cabling and maintaining the devices.
 - Allow the status LEDs to be clearly visible.
- ◆ Make sure the twisted-pair Ethernet cable is always routed away from power lines, radios, transmitters or any other electrical interference.
- ◆ Make sure that GEL2P-ESW10G 10Port Series Switch is connected to a separate grounded power outlet that provides 100 to 240 VAC, 50 to 60 Hz.

ETHERNET CABLING

To ensure proper operation when installing the switch into a network, make sure that the current cables are suitable for 100BASE-TX or 1000BASE-T operation. Check the following criteria against the current installation of your network:

- ◆ Cable type: Unshielded twisted pair (UTP) or shielded twisted pair (STP) cable with RJ-45 connectors; Category 5 or Category 5e with maximum length of 100 meters is recommend 100BASE-TX, and Category 5e or 6 with maximum length of 100 meters is recommend for 1000BASE-T.
- ◆ Protection from radio frequency interference emissions.
- ◆ Electrical surge suppression.
- ◆ Separation of electrical wires and data based network wiring.
- ◆ Safe connections with no damaged cables, connectors or shields.

RJ-45 Connections

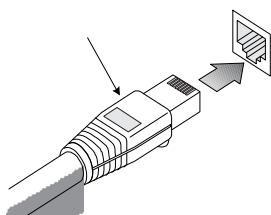

SFP Transceiver

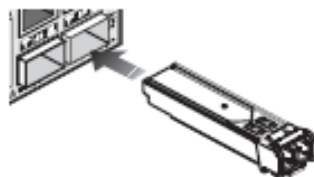

EQUIPMENT CHECKLIST

After unpacking this switch, please check the contents to be sure you have received all the components. Then, before beginning the installation, be sure you have all other necessary installation equipment.

PACKAGE CONTENTS

- GEL2P-ESW10G 10 Port Series GbE Management Switch
- Four adhesive rubber feet
- Mounting Accessory (for 19" Rack Shelf, Optional)
- This Installation Guide
- User's Manual CD
- AC Power Cord
- RJ-45 Console Cable



NOTE: Please notify your sales representative immediately if any of the aforementioned items is missing or damaged.



WARNING: The mini-GBICs are Class 1 laser devices. Avoid direct eye exposure to the beam coming from the transmit port.

MOUNTING

The switch can be mounted in a standard 19-inch equipment rack or on a desktop or shelf. Mounting instructions for each type of site as follow.

RACK MOUNTING

Before rack mounting the switch, please pay attention to the following factors:

- Temperature: Since the temperature within a rack assembly may be higher than the ambient room temperature, check that the rack-environment temperature is within the specified operating temperature range (0 to 45 °C).
- Mechanical Loading: Do not place any equipment on top of a rack-mounted unit.

- Circuit Overloading: Be sure that the supply circuit to the rack assembly is not overloaded.
- Grounding: Rack-mounted equipment should be properly grounded.

TO Rack-mount Devices:

Step1. Attach the brackets to the device using the screws provided in the Mounting Accessory.

Attaching the Brackets

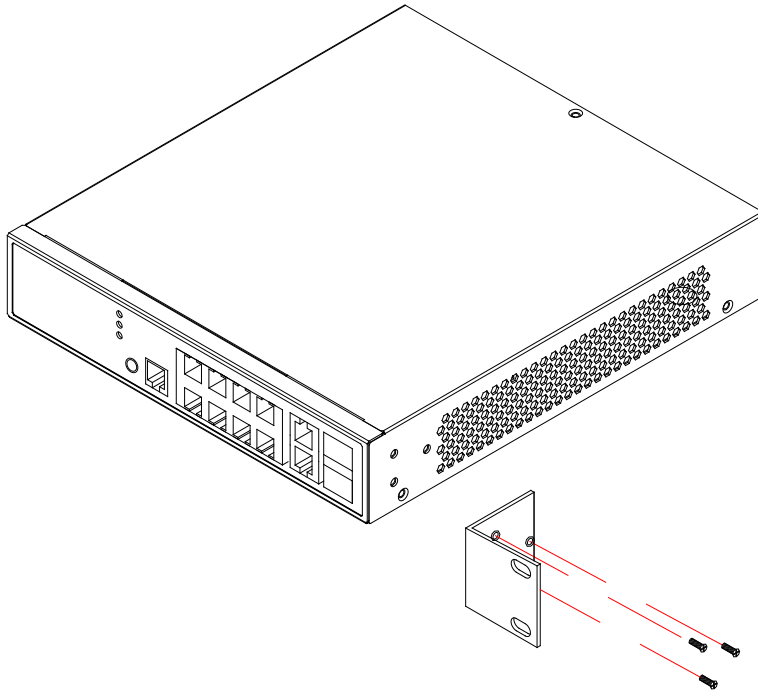

Step2. Mount the device in the rack (Via Optional Rack-Mount kit), using four rack-mounting screws (not provided). Be sure to secure the lower rack-mounting screws first to prevent the brackets being bent by the weight of the switch.

Installing the switch in a Rack

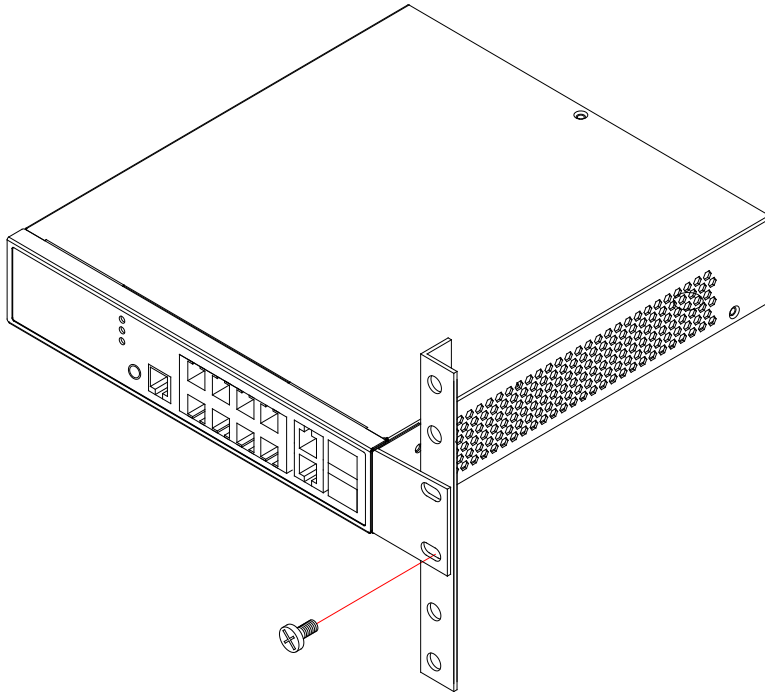

Step3. If installing a single switch only, turn to “Connection to a Power Source” at the end of this chapter.

Step4. If installing multiple switches, mount them in the rack, one below the other, in any order.

DESKTOP OR SHELF MOUNTING:

- Step1.** Attach the four adhesive rubber feet to the bottom of the first switch.
- Step2.** Set the device on a flat surface near an AC power source, making sure there are at least two inches of space on all sides for proper air flow.
- Step3.** If installing a single switch only, go to "[Connecting to a Power Source](#)" at the end of this Chapter.
- Step4.** If installing multiple switches, attach four adhesive feet to each one. Place each device squarely on top of the one below, in any order.

INSTALLING AN OPTIONAL SFP TRANSCEIVER

You can install or remove a mini-GBIC SFP from a mini-GBIC slot (Except GEL2-ESW08) without having to power off the switch. Use only Manufacture mini-GBIC.



NOTE:

- The mini-GBIC slots are shared with the two 10/ 100/ 1000Base-T RJ-45 ports. If a mini-GBIC is installed in a slot, the associated RJ-45 port is disabled and cannot be used (GEL2-ESW10G only)
 - The mini-GBIC ports operate only at full duplex. Half duplex operation is not supported.
 - Ensure the network cable is NOT connected when you install or remove a mini-GBIC.
-



CAUTION: Use only supported genuine Manufacture mini-GBICs with your switch. Non-Manufacture mini-GBIC might have compatible issue, and their use may result in product malfunction.

Inserting an SFP Transceiver into a Slot

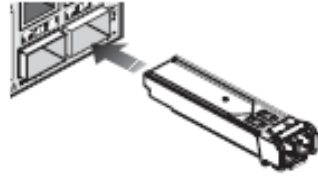

The SFP slots support the following optional SFP transceivers:

Model Name	Description
	1000Base-SX GE SFP Fiber Module, LC Multi-Mode 850nm
	1000Base-SX GE SFP Fiber Module, LC Multi-Mode 1310nm 2km
	1000Base-LX GE SFP Fiber Module, LC Single-Mode 10km
	1000Base-LX GE SFP Fiber Module, LC Single-Mode 30km
	1000Base-LX GE SFP Fiber Module, LC Single-Mode 50km
	1000Base-LX GE SFP Fiber Module, LC Single-Mode 50km
	1000Base-LX GE SFP Fiber Module, Bidi LC Single-Mode 10km, 1310nm
	1000Base-LX GE SFP Fiber Module, Bidi LC Single-Mode 10km, 1550nm
	1000Base-LX GE SFP Fiber Module, Bidi LC Single-Mode 20km, 1550nm
	1000Base-LX GE SFP Fiber Module, Bidi LC Single-Mode 20km, 1310nm
	100Base-FX FE SFP Fiber Module, LC Multi-Mode
	100Base-FX FE SFP Fiber Module, LC Single-Mode 20km



CAUTION: We recommend the SFP Transceiver from the following vendors:

- Manufacture Corporation
 - Agilent Technologies
 - AVAGO Technologies
 - Finisar Corporation
-

TO Install a SFP transceiver, do the following:

- Step1.** Consider network and cabling requirements to select an appropriate SFP transceiver type.
- Step2.** Insert the transceiver with the optical connector facing outward and the slot connector facing down. Note that SFP transceivers are keyed so they can only be installed in one orientation.

Step3. Slide the SFP transceiver into the slot until it clicks into place.



NOTE: SFP transceivers are not provided in the switch package.

CONNECTING TO A POWER SOURCE

You can plug or remove power cord from AC power socket , to switch the power on and off .

Inserting the Power Cord to AC Power Socket

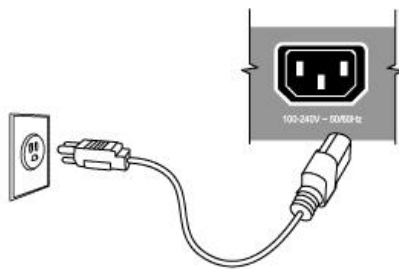

Step1. Insert the power cable plug directly into the AC Socket located at the back of the switch.

Step2. Plug the other end of the cable into a grounded, 3-Pin, AC power source.

Step3. Check the front-panel LEDs as the device is powered on to be sure the POWER LED is lit. If not, check that the power cable is correctly plugged in.



WARNING: For International use, you may need to change the AC line cord. You must use a line cord set that has been approved for the socket type in your country.

CONNECTING TO THE CONSOLE PORT

The RJ-45 serial port on the switch's front panel is used to connect to the switch for out-of-band console configuration. The command-line-driven configuration program can be accessed from a terminal or a PC running a terminal emulation program. The pin assignments used to connect to the serial port are provided in the following table

Serial Port (RJ-45) Pin-Out

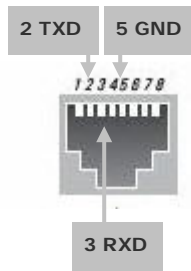

WIRING MAP FOR SERIAL CABLE

Serial Cable Wiring

Switch's 8-Pin Serial Port	Null Modem	PC's 9-Pin DTE Port
6 RXD (receive data)	←-----	3 TXD (transmit data)
3 TXD (transmit data)	-----→	2 RXD (receive data)
5 SGND (Signal ground)	-----	5 SGND (Signal ground)



NOTE: No other pins are used.

Plug in the Console Port

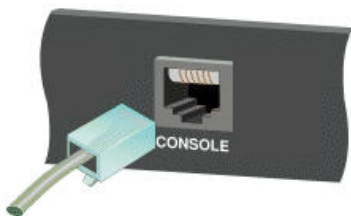

The serial port's configuration requirements are as follows:

- ◆ Default Baud rate—115,200 bps
- ◆ Character Size—8 Characters
- ◆ Parity—None
- ◆ Stop bit—One
- ◆ Data bits—8
- ◆ Flow control—none

Operation of Web-based Management

The default values of the switch is listed in the table below:

IP Address	192.168.1.1
Subnet Mask	255.255.255.0
Default Gateway	192.168.1.254
Username	admin
Password	

To access the web management of switch enter the default IP Address in web browser and hit enter. E.g <http://192.168.1.1>

Once you have entered the IP Address into the web browser you will be prompted to enter a Username and Password in order to access the web management interface. Enter the default values as shown in the table above.



The image shows a web-based login interface. It consists of a light gray background with a white text input field at the top containing a vertical cursor. Below this is another white text input field with the placeholder text "Password". At the bottom of the interface is a prominent blue button with the word "Login" written in white text.



NOTE: For full configuration details of the switch please refer to the User Manual

MAKING NETWORK CONNECTIONS

CONNECTING NETWORK DEVICES

The switch is designed to be connected to 10, 100 or 1000Mbps network cards in PCs and servers, as well as to other switches and hubs. It may also be connected to remote devices using optional SFP transceivers.

TWISTED-PAIR DEVICES

Each device requires an unshielded twisted-pair (UTP) cable with RJ-45 connectors at both ends. Use Category 5, 5e or 6 cables for 1000BASE-T connections, Category 5 or better for 100BASE-TX connections.

CABLING GUIDELINES

The RJ-45 ports on the switch support automatic MDI/MDI-X pinout configuration, so you can use standard straight-through twisted-pair cables to connect to any other network device (PCs, servers, switches, routers, or hubs).



CAUTION: Do not plug a phone jack connector into an RJ-45 port. This will damage the switch. Use only twisted-pair cables with RJ-45 connectors that conform to FCC standards.

CONNECTING TO PCS, SERVERS, HUBS AND SWITCHES

Step 1. Attach one end of a twisted-pair cable segment to the device's RJ-45 connector.

Making Twisted-Pair Connections

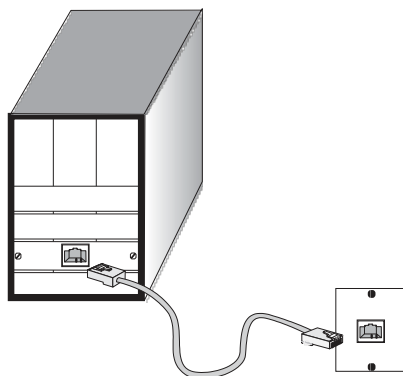

Step2. If the device is a network card and the switch is in the wiring closet, attach the other end of the cable segment to a modular wall outlet that is connected to the wiring closet. (See the section "[Network Wiring Connections](#).") Otherwise, attach the other end to an available port on the switch.

Make sure each twisted pair cable does not exceed 100 meters (328 ft) in length.



NOTE: Avoid using flow control on a port connected to a hub unless it is actually required to solve a problem. Otherwise back pressure jamming signals may degrade overall performance for the segment attached to the hub.

Step3. As each connection is made, the Link LED (on the switch) corresponding to each port will light green (1000 Mbps) or amber (100 Mbps) to indicate that the connection is valid.

NETWORK WIRING CONNECTIONS

Today, the punch-down block is an integral part of many of the newer equipment racks. It is actually part of the patch panel. Instructions for making connections in the wiring closet with this type of equipment follows.

Step1. Attach one end of a patch cable to an available port on the switch, and the other end to the patch panel.

Step2. If not already in place, attach one end of a cable segment to the back of the patch panel where the punch-down block is located, and the other end to a modular wall outlet.

Step3. Label the cables to simplify future troubleshooting. See "[Cable Labeling and Connection Records](#)".

Network Wiring Connections

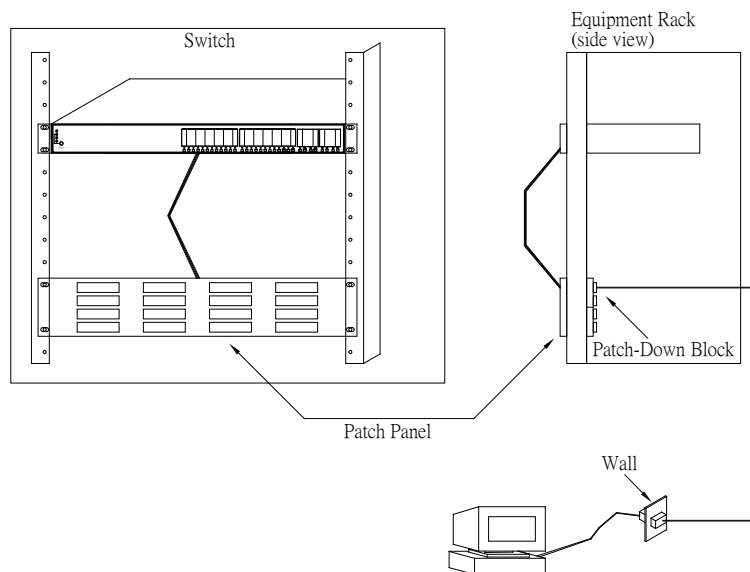

FIBER OPTIC SFP DEVICES

An optional Gigabit SFP transceiver can be used for a backbone connection between switches, or for connecting to a high-speed server.

Each single-mode fiber port requires 9/125 micron single-mode fiber optic cable with an LC connector at both ends. Each multimode fiber optic port requires 50/125 or 62.5/125 micron multimode fiber optic cabling with an LC connector at both ends.



WARNING: This switch uses lasers to transmit signals over fiber optic cable. The lasers are inherently eye safe in normal operation. However, user should never look directly at a transmit port when it is powered on.

WARNING: When selecting a fiber SFP device, considering safety, please make sure that it can function at a temperature that is not less than the recommended maximum operational temperature of the product. You must also use an approved Laser SFP transceiver.

- Step1.** Remove and keep the LC port's rubber plug. When not connected to a fiber cable, the rubber plug should be replaced to protect the optics.
- Step2.** Check that the fiber terminators are clean. You can clean the cable plugs by wiping them gently with a clean tissue or cotton ball moistened with a little ethanol. Dirty fiber terminators on fiber optic cables will impair the quality of the light transmitted through the cable and lead to degraded performance on the port.
- Step3.** Connect one end of the cable to the LC port on the switch and the other end to the LC port on the other device. Since LC connectors are keyed, the cable can be attached in only one orientation.
- Step4.** As a connection is made, check the Link LED on the switch corresponding to the port to be sure that the connection is valid.

The fiber optic ports operate at 1 Gbps. The maximum length for fiber optic cable operating at Gigabit speed will depend on the fiber type as listed under "[1000 Mbps Gigabit Ethernet Collision Domain](#)".

CONNECTIVITY RULES

When adding hubs to your network, please note that because switches break up the path for connected devices into separate collision domains, you should not include the switch or connected cabling in your calculations for cascade length involving other devices.

1000BASE-T CABLE REQUIREMENTS

All Category 5 UTP cables that are used for 100BASE-TX connections should also work for 1000BASE-T, providing that all four wire pairs are connected. However, it is recommended that for all critical connections, or any new cable installations, Category 5e or Category 6 cable should be used. The Category 5e and 6 specifications include test parameters that are only recommendations for Category 5. Therefore, the first step in preparing existing Category 5 cabling for running 1000BASE-T is a simple test of the cable installation to be sure that it complies with the IEEE 802.3-2005 standards

1000 MBPS GIGABIT ETHERNET COLLISION DOMAIN

Maximum 1000BASE-T Gigabit Ethernet Cable Length

Cable Type	Maximum Cable Length	Connector
Category 5, 5e or 6 100-ohm UTP or STP	100.m (328 ft)	RJ-45

Table 6: Maximum 1000BASE-SX Gigabit Fiber Cable Lengths

Fiber Size	Fiber Bandwidth	Maximum Cable Length	Connector
62.5/125 micron multimode fiber	160 MHz/km	220 m (722 ft)	LC
	200 MHz/km	275 m (902 ft)	LC
50/125 micron multimode fiber	400 MHz/km	500 m (1641 ft)	LC
	500 MHz/km	550 m (1805 ft)	LC

Maximum 1000BASE-LX/LHX/XD/ZX Gigabit Fiber Cable Length

Fiber Size	Fiber Bandwidth	Maximum Cable Length	Connector
9/125 micron single-mode fiber 1310nm	N/A	10km (6.2 miles)	LC
9/125 micron single-mode fiber 1550nm	N/A	30km (18.64 miles)	LC
		50km (31.06 miles)	LC

Maximum 1000BASE-LX Single Fiber Gigabit Fiber Cable Length

Fiber Size	Fiber Bandwidth	Maximum Cable Length	Connector
Single-mode TX-1310nm RX-1550nm	N/A	20km (12.42miles)	BIDI
			LC
Single-mode TX-1550nm RX-1310nm	N/A	20km (12.42miles)	BIDI
			LC

100 MBPS FAST ETHERNET COLLISION DOMAIN

Maximum Fast Ethernet Cable Lengths

Cable Type	Maximum Cable Length	Connector
Category 5, 5e or 6 100-ohm UTP or STP	100.m (328 ft)	RJ-45

CABLE LABELING AND CONNECTION RECORDS

When planning a network installation, it is essential to label the opposing ends of cables and to record where each cable is connected. This will allow user to easily locate inter-connected devices, isolate faults and change your topology without need for unnecessary time consumption.

To best manage the physical implementations of your network, follow these guidelines:

- ◆ Clearly label the opposing ends of each cable.
- ◆ Using your building's floor plans, draw a map of the location of all network-connected equipment. For each piece of equipment, identify the devices to which it is connected.
- ◆ Note the length of each cable and the maximum cable length supported by the switch ports.
- ◆ For ease of understanding, use a location-based key when assigning prefixes to your cable labeling.
- ◆ Use sequential numbers for cables that originate from the same equipment.
- ◆ Differentiate between racks by naming accordingly.
- ◆ Label each separate piece of equipment.
- ◆ Display a copy of your equipment map, including keys to all abbreviations at each equipment rack.

TROUBLESHOOTING

Basic Troubleshooting Tips

Most problems are caused by the following situations. Check for these items first when starting your troubleshooting:

■ **Connecting to devices that have a fixed full-duplex configuration.**

The RJ-45 ports are configured as "Auto". That is, when connecting to attach devices, the switch will operate in one of two ways to determine the link speed and the communication mode (half duplex or full duplex):

- ◆ If the connected device is also configured to Auto, the switch will automatically negotiate both link speed and communication mode.
- ◆ If the connected device has a fixed configuration, for example 100Mbps, at half or full duplex, the switch will automatically sense the link speed, but will default to a communication mode of *half duplex*.

Because the GEL2P-ESW10G Switch devices behave in this way (in *compliance with the IEEE802.3 standard*), if a device connected to the switch has a fixed configuration at full duplex, the device will not connect correctly to the switch. The result will be high error rates and very inefficient communications between the switch and the device.

Make sure all devices connected to the GEL2P-ESW10G Switch devices are configured to auto negotiate, or are configured to connect at half duplex (all hubs are configured this way, for example).

- **Faulty or loose cables.** Look for loose or obviously faulty connections. If they appear to be OK, make sure the connections are snug. If that does not correct the problem, try a different cable.
- **Non-standard cables.** Non-standard and miswired cables may cause network collisions and other network problems, and can seriously impair network performance. Use a new correctly-wired cable. For pinouts and correct cable wiring. A category 5 cable tester is a recommended tool for every 100Base-TX and 1000Base-T network installation.
- **Improper Network Topologies.** It is important to make sure you have a valid network topology. If you no longer experience the problems, the new topology is probably at fault. In addition, you should make sure that your network topology contains *no data path loops*.

■ **Check the port configuration.**

A port on your Switch may not be operating as you expect because it has been put into a “ blocking” state by Spanning Tree, GVRP (automatic VLANs), or LACP (automatic trunking). (Note that the normal operation of the Spanning Tree, GVRP, and LACP features may put the port in a blocking state.) Or, the port just may have been configured as disabled through software.

Troubleshooting Chart

Symptom	Action
POWER LED is Off	<ul style="list-style-type: none">◆ Check connections between the switch, the power cord and the wall outlet.◆ Contact your dealer for assistance.
Link LED is Off	<ul style="list-style-type: none">◆ Verify that the switch and attached device are powered on.◆ Be sure the cable is plugged into the switch and corresponding device.◆ If the switch is installed in a rack, check the connections to the punch-down block and patch panel.◆ Verify that the proper cable types is used and its length does not exceed specified limits.◆ Check the adapter on the attached device and cable connections for possible defects. Replace the defective adapter or cable if necessary.

POWER AND COOLING PROBLEMS

Installation

If the power indicator does not turn on when the power cord is plugged in, you may have a problem with the power outlet, power cord, or internal power supply. However, if the unit powers off after running for a while, check for loose power connections, power losses or surges at the power outlet. If you still cannot isolate the problem, the internal power supply may be defective. Verify that all system components have been properly installed. If one or more components appear to be malfunctioning (such as the power cord or network cabling), test them in an alternate environment where you are sure that all the other components are functioning properly.

IN-BAND ACCESS

You can access the management agent in the switch from anywhere within the attached network using Telnet, a web browser. However, you must first configure the switch with a valid IP address, subnet mask, and default gateway. If you have trouble establishing a link to the management agent, check to see if you have a valid network connection. Then verify that you entered the correct IP address. Also, be sure the port through which you are connecting to the switch has not been disabled. If it has not been disabled, then check the network cabling that runs between your remote location and the switch.



NOTE: The management agent accepts up to four simultaneous Telnet sessions. If the maximum number of sessions already exists, an additional Telnet connection will not be able to log into the system.

CABLES

TWISTED-PAIR CABLE AND PIN ASSIGNMENTS

For 10/100BASE-TX connections, the twisted-pair cable must have two pairs of wires. For 1000BASE-T connections the twisted-pair cable must have four pairs of wires. Each wire pair is identified by two different colors. For example, one wire might be green and the other, green with white stripes. Also, an RJ-45 connector must be attached to both ends of the cable.



CAUTION: DO NOT plug a phone jack connector into any RJ-45 port. Use only twisted-pair cables with RJ-45 connectors that conform with FCC standards.

CAUTION: Each wire pair must be attached to the RJ-45 connectors in a specific orientation.

The figure below illustrates how the pins on the RJ-45 connector are numbered. Be sure to hold the connectors in the same orientation when attaching the wires to the pins.

RJ-45 Connector Pin Numbers

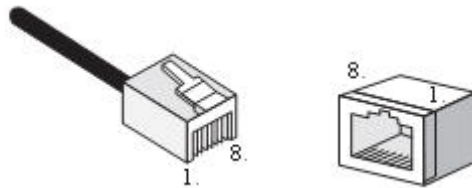

10BASE-T/100BASE-TX PIN ASSIGNMENTS

Use unshielded twisted-pair (UTP) or shielded twisted-pair (STP) cable for RJ-45 connections: 100-ohm Category 3 or better cable for 10 Mbps connections, or 100-ohm Category 5 or better cable for 100 Mbps connections. Also be sure that the length of any twisted-pair connection does not exceed 100 meters (328 feet).

The RJ-45 ports on the switch base unit support automatic MDI/MDI-X operation, so you can use straight-through cables for all network connections to PCs or servers, or to other switches or hubs. In straight-through cable, pins 1, 2, 3, and 6, at one end of the cable, are connected straight through to pins 1, 2, 3, and 6 at the other end of the cable. When using any RJ-45 port on this switch, you can use either straight-through or crossover cable.

10/100BASE-TX MDI and MDI-X Port Pinouts

Pin	MDI Signal Name	MDI-X Signal Name
1	Transmit Data plus (TD+)	Receive Data plus (RD+)
2	Transmit Data minus (TD-)	Receive Data minus (RD-)
3	Receive Data plus (RD+)	Transmit Data plus (TD+)
6	Receive Data minus (RD-)	Transmit Data minus (TD-)
4, 5, 7, 8	Not used	Not used



NOTE: The "+" and "-" signs represent the polarity of the wires that make up each wire pair.

STRAIGHT-THROUGH WIRING

If the twisted-pair cable is to join two ports and only one of the ports has an internal crossover (MDI-X), the two pairs of wires must be straight-through. (When auto-negotiation is enabled for any RJ-45 port on this switch, you can use either straight-through or crossover cable to connect to any device type.)

You must connect all four wire pairs as shown in the following diagram to support Gigabit Ethernet.

Straight-through Wiring

**EIA/TIA 568B RJ-45 Wiring Standard
10/100BASE-TX Straight-through Cable**

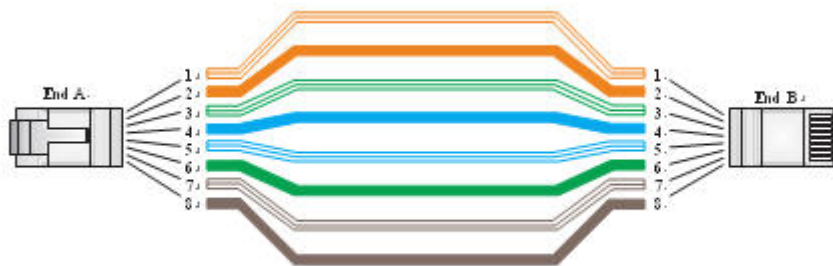

CROSSOVER WIRING

If the twisted-pair cable is to join two ports and either both ports are labeled with an "X" (MDI-X) or neither port is labeled with an "X" (MDI), a crossover must be implemented in the wiring. (When auto-negotiation is enabled for any RJ-45 port on this switch, you can use either straight-through or crossover cable to connect to any device type.)

You must connect all four wire pairs as shown in the following diagram to support Gigabit Ethernet.

Crossover Wiring

**EIA/TIA 568B RJ-45 Wiring Standard
10/100BASE-TX Crossover Cable**



1000BASE-T PIN ASSIGNMENTS

All 1000BASE-T ports support automatic MDI/MDI-X operation, so you can use straight-through cables for all network connections to PCs or servers, or to other switches or hubs.

The table below shows the 1000BASE-T MDI and MDI-X port pinouts. These ports require that all four pairs of wires be connected. Note that for 1000BASE-T operation, all four pairs of wires are used for both transmit and receive.

Use 100-ohm Category 5, 5e or 6 unshielded twisted-pair (UTP) or shielded twisted-pair (STP) cable for 1000BASE-T connections. Also be sure that the length of any twisted-pair connection does not exceed 100 meters (328 feet).

1000BASE-T MDI and MDI-X Port Pinouts

Pin	MDI Signal Name	MDI-X Signal Name
1	Bi-directional Pair A Plus (BI_DA+)	Bi-directional Pair B Plus (BI_DB+)
2	Bi-directional Pair A Minus (BI_DA-)	Bi-directional Pair B Minus (BI_DB-)
3	Bi-directional Pair B Plus (BI_DB+)	Bi-directional Pair A Plus (BI_DA+)
4	Bi-directional Pair C Plus (BI_DC+)	Bi-directional Pair D Plus (BI_DD+)
5	Bi-directional Pair C Minus (BI_DC-)	Bi-directional Pair D Minus (BI_DD-)
6	Bi-directional Pair B Minus (BI_DB-)	Bi-directional Pair A Minus (BI_DA-)
7	Bi-directional Pair D Plus (BI_DD+)	Bi-directional Pair C Plus (BI_DC+)
8	Bi-directional Pair D Minus (BI_DD-)	Bi-directional Pair C Minus (BI_DC-)

CABLE TESTING FOR EXISTING CATEGORY 5 CABLE

Installed Category 5 cabling must pass tests for Attenuation, Near-End Crosstalk (NEXT), and Far-End Crosstalk (FEXT). This cable testing information is specified in the ANSI/TIA/EIA-TSB-67 standard. Additionally, cables must also pass test parameters for Return Loss and Equal-Level Far-End Crosstalk (ELFEXT). These tests are specified in the ANSI/TIA/EIA-TSB-95 Bulletin, "The Additional Transmission Performance Guidelines for 100 Ohm 4-Pair Category 5 Cabling."



NOTE: That when testing your cable installation, be sure to include all patch cables between switches and end devices.

ADJUSTING EXISTING CATEGORY 5 CABLING TO RUN 1000BASE-T

If your existing Category 5 installation does not meet one of the test parameters for 1000BASE-T, there are basically three measures that can be applied to try and correct the problem:

1. Replace any Category 5 patch cables with high-performance Category 5e or Category 6 cables.
2. Reduce the number of connectors used in the link.
3. Reconnect some of the connectors in the link.

FIBER STANDARDS

The International Telecommunication Union (ITU-T) has standardized various fiber types for data networks. These are summarized in the following table.

Fiber Standards

ITU-T Standard	Description	Application
G.651	Multimode Fiber 50/125-micron core	Short-reach connections in the 1300- nm or 850-nm band
G.652	Non-Dispersion-Shifted Fiber Single-mode, 9/125-micron core	Longer spans and extended reach. Optimized for operation in the 1310- nm band, but can also be used in the 1550-nm band
G.652.C	Low Water Peak Non-Dispersion-Shifted Fiber Single-mode, 9/125-micron core	Longer spans and extended reach. Optimized for wavelength-division multiplexing (WDM) transmission across wavelengths from 1285 to 1625 nm. The zero dispersion wavelength is in the 1310-nm region.
G.653	Dispersion-Shifted Fiber Single-mode, 9/125-micron core	Longer spans and extended reach. Optimized for operation in the region from 1500 to 1600-nm.
G.654	1550-nm Loss-Minimized Fiber Single-mode, 9/125-micron core	Extended long-haul applications. Optimized for high-power transmission in the 1500 to 1600-nm region, with low loss in the 1550-nm band.
G.655	Non-Zero Dispersion-Shifted Fiber Single-mode, 9/125-micron core	Extended long-haul applications. Optimized for high-power dense wavelength-division multiplexing (DWDM) operation in the region from 1500 to 1600-nm.

SPECIFICATIONS

PHYSICAL CHARACTERISTICS

PORTS	8 10/100/1000Mbps UTP 2 GbE Combo Port TP/ (100/1000M) SFP
NETWORK INTERFACE	Ports 1-8: RJ-45 connector, auto MDI/X 10BASE-T: RJ-45 (100-ohm, UTP cable; Category 3 or better) 100BASE-TX: RJ-45 (100-ohm, UTP cable; Category 5 or better) 1000BASE-T: RJ-45 (100-ohm, UTP or STP cable; Category 5, 5e or 6) *Maximum Cable Length - 100 m (328 ft) Ports 9-10: RJ45/SFP Combo ports
BUFFER ARCHITECTURE	512KB on-chip frame buffer
AGGREGATE BANDWIDTH	20 Gbps for GEL2P-ESW10G
SWITCHING DATABASE	8K MAC address entries
LEDS	System: POWER TP Port: status (LINK/ACT), 10/100/1000M SFP Port: status (LINK/ACT/SPD), 100/1000M
SIZE	44(H) x 220(W) x 242(D)mm
TEMPERATURE	Operating: 0°C to 45°C (32°F to 113°F)
HUMIDITY	Operating: 10% to 90% (non-condensing)
POWER INPUT	100~240VAC, 50~60Hz
POWER Budget	8 Watts maximum

SWITCH FEATURES

FORWARDING MODE	Store-and-forward
------------------------	-------------------

THROUGHPUT	14.880 Mpps
FLOW CONTROL	Full Duplex: IEEE 802.3x Half Duplex: Back pressure

MANAGEMENT FEATURES

IN-BAND MANAGEMENT	SSH/SSL, Telnet, SNMP, or HTTP
---------------------------	--------------------------------

OUT-OF-BAND MANAGEMENT	RJ-45 console port
-------------------------------	--------------------

SOFTWARE LOADING	HTTP, TFTP in-band, Console out-of-band
-------------------------	---

STANDARDS

I	IEEE 802.3 => 10Base-T Ethernet (Twisted-pair Copper)
	IEEE 802.3u => 100Base-TX Ethernet (Twisted-pair Copper)
	IEEE 802.3ab => 1000Base-TX Ethernet (Twisted-pair Copper)
	IEEE 802.3z => 1000Base-X Ethernet
	IEEE 802.3x => Flow Control Capability
	ANSI/IEEE 802.3 => Auto-negotiation
	IEEE 802.1Q => VLAN
	IEEE 802.1p => Class of Service
	IEEE 802.1X => Access Control
	IEEE 802.1D => Spanning Tree
	IEEE 802.1w => Rapid Spanning Tree
	IEEE 802.1s => Multiple Spanning Tree
	IEEE 802.3ad => Link Aggregation Control Protocol (LACP)
	IEEE 802.1AB => Link Layer Discovery Protocol (LLDP)

COMPLIANCES

EMISSIONS

EN55022 (CISPR 22) Class A EN 61000-3

FCC Class A

CE Mark

IMMUNITY

EN 61000-4-2/3/4/5/6/8/11

EN 55024

COMPLIANCES

10BASE-T	IEEE 802.3 specification for 10 Mbps Ethernet over two pairs of Category 3, 4, or 5 UTP cable
100BASE-TX	IEEE 802.3u specification for 100 Mbps Ethernet over two pairs of Category 5 UTP cable
1000BASE-LH	Specification for long-haul Gigabit Ethernet over two strands of 9/125 micron core fiber cable
1000BASE-LX	IEEE 802.3z specification for Gigabit Ethernet over two strands of 50/125, 62.5/125 or 9/125 micron core fiber cable.
1000BASE-SX	IEEE 802.3z specification for Gigabit Ethernet over two strands of 50/125 or 62.5/125 micron core fiber cable.
1000BASE-T	IEEE 802.3ab specification for Gigabit Ethernet over 100-ohm Category 5, 5e or 6 twisted-pair cable (using all four wire pairs).
AUTO-NEGOTIATION	Signaling method allowing each node to select its optimum operational mode (e.g., speed and duplex mode) based on the capabilities of the node to which it is connected.
BANDWIDTH	The difference between the highest and lowest frequencies available for network signals. Also synonymous with wire speed, the actual speed of the data transmission along the cable.
COLLISION DOMAIN	Single CSMA/CD LAN segment.
CSMA/CD	CSMA/CD (Carrier Sense Multiple Access/Collision Detect) is the communication method employed by Ethernet, Fast Ethernet, and Gigabit Ethernet.
END STATION	A workstation, server, or other device that does not forward traffic.
ETHERNET	A network communication system developed and standardized by DEC, Intel, and Xerox, were using baseband transmission, CSMA/CD access, logical bus topology, and coaxial cable. The successor IEEE 802.3 standard provides for integration into the OSI model and extends the physical layer and media with repeaters and implementations that operate on fiber, thin coax and twisted-pair cable.
FAST ETHERNET	A 100 Mbps network communication system based on Ethernet and the CSMA/ CD access method.

FULL DUPLEX	Transmission method that allows two network devices to transmit and receive concurrently, effectively doubling the bandwidth of that link.
GIGABIT ETHERNET	A 1000 Mbps network communication system based on Ethernet and the CSMA/ CD access method.
IEEE	Institute of Electrical and Electronic Engineers.
IEEE 802.3	Defines carrier sense multiple access with collision detection (CSMA/CD) access method and physical layer specifications.
IEEE 802.3AB	Defines CSMA/CD access method and physical layer specifications for 1000BASE-T Gigabit Ethernet. (Now incorporated in IEEE 802.3-2005.)
IEEE 802.3U	Defines CSMA/CD access method and physical layer specifications for 100BASE-TX Fast Ethernet. (Now incorporated in IEEE 802.3-2005.)
IEEE 802.3X	Defines Ethernet frame start/stop requests and timers used for flow control on full-duplex links. (Now incorporated in IEEE 802.3-2005.)
IEEE 802.3Z	Defines CSMA/CD access method and physical layer specifications for 1000BASE Gigabit Ethernet. (Now incorporated in IEEE 802.3-2005.)
LAN SEGMENT	Separate LAN or collision domain.
LED	Light emitting diode used for monitoring a device or network condition.
LOCAL AREA NETWORK (LAN)	A group of interconnected computer and support devices .
MEDIA ACCESS CONTROL (MAC)	A portion of the networking protocol that governs access to the transmission medium, facilitating the exchange of data between network nodes.
MIB	An acronym for Management Information Base. It is a set of database objects that contains information about the device.
MODAL BANDWIDTH	Bandwidth for multimode fiber is referred to as modal bandwidth because it varies with the modal field (or core diameter) of the fiber. Modal bandwidth is specified in units of MHz per km, which indicates the amount of bandwidth supported by the fiber for a one km distance.
NETWORK DIAMETER	Wire distance between two end stations in the same collision domain.
RJ-45 CONNECTOR	A connector for twisted-pair wiring.

SWITCHED PORTS	Ports that are on separate collision domains or LAN segments.
TIA	Telecommunications Industry Association.
TRANSMISSION CONTROL PROTOCOL/INTERNET PROTOCOL (TCP/IP)	Protocol suite that includes TCP as the primary transport protocol, and IP as the network layer protocol.
USER DATAGRAM PROTOCOL (UDP)	<p>UDP provides a datagram mode for the packet-switched communications. It uses the IP as the underlying transport mechanism to provide access to IP-like services.</p> <p>UDP packets are delivered just like IP packets – connection-less data grams that may be discarded before reaching their targets. UDP is useful when TCP would be too complex, too slow, or just unnecessary.</p>
UTP	Unshielded twisted-pair cable.
VIRTUAL LAN (VLAN)	A Virtual LAN is a collection of network nodes that share the same collision domain regardless of their physical location or connection point in the network. A VLAN serves as a logical workgroup with no physical barriers, allowing users to share information and resources as though located on the same LAN.