

RP-MGT1000 | RP-MGT1000A **Gigabit Copper SFP Transceiver**

RP-MGT1000 Copper Small Form Pluggable (SFP) transceivers is high performance, cost effective module compliant with the Gigabit Ethernet and 1000BASE-T standards as specified in IEEE 802.3-2002 and IEEE 802.3ab, which supporting 1000Mbps data-rate up to 100 meters reach over unshielded twisted-pair category 5 cable. The module supports 1000 Mbps full duplex data-links with 5-level Pulse Amplitude Modulation (PAM) signals. The module provides standard serial ID information compliant with SFP MSA, which can be accessed with address of A0h via the 2-wire serial CMOS EEPROM protocol. The physical IC can also be accessed via 2-wire serial bus at address A0h.



Features

- Up to 1.25Gb/s bi-directional data links
- Hot-pluggable SFP footprint
- Fully metallic enclosure for low EMI
- Low power dissipation (1.05 W typical)
- Compact RJ-45 connector assembly
- Compatible with RoHS and lead-free
- Access to physical layer IC via 2-wire serial bus
- 1000 BASE-T operation in host systems with SERDES interface (RP-MGT1000)
- 10/100/1000Mbps compliant in host systems with SGMII interface (RP-MGT1000A)
- Operating case temperature range of 0°C to +70°C

Applications

- 1.25 Gigabit Ethernet over Cat 5 cable

Pin Definition

Pin Diagram

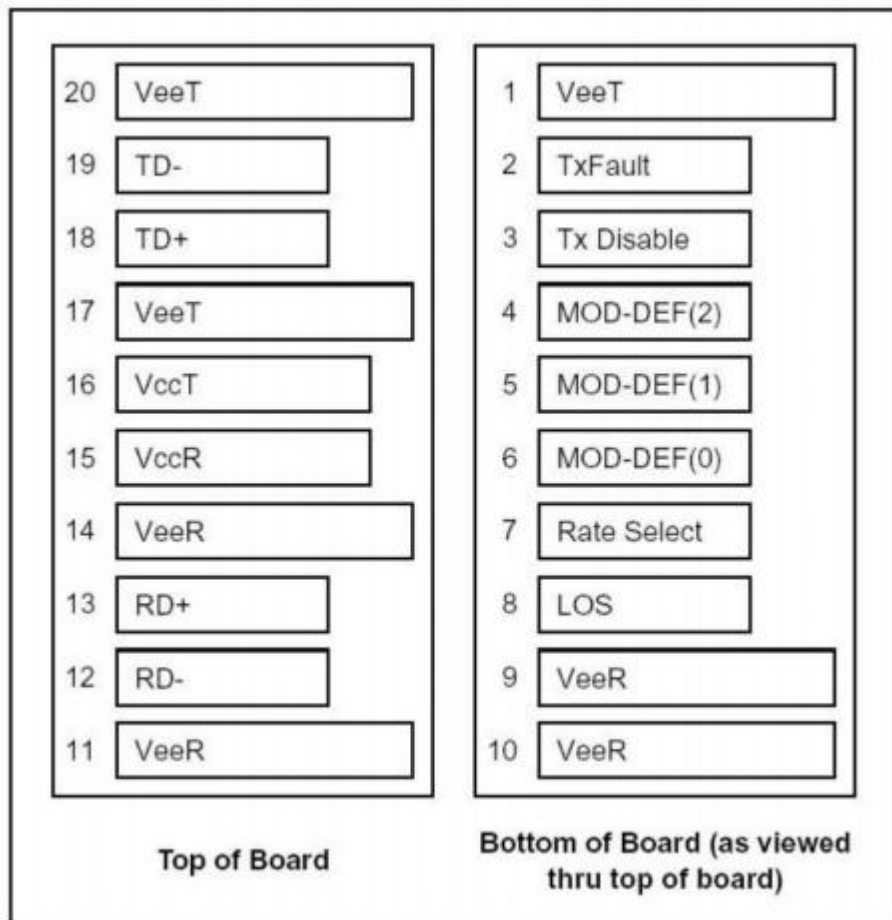



Pin Descriptions

Pin Descriptions				
Pin	Signal Name	Description	Plug Seq.	Notes
1	VeeT	Transmitter Ground	1	
2	TX FAULT	Transmitter Fault Indication	3	Note1
3	TX DISABLE	Transmitter Disable	3	Note2
4	MOD_DEF(2)	SDA Serial Data Signal	3	Note3
5	MOD_DEF(1)	SCL Serial Clock Signal	3	Note3
6	MOD_DEF(0)	TTL Low	3	Note3
7	Rate Select	Not Connected	3	
8	LOS	Loss of Signal	3	Note4
9	Veer	Receiver ground	1	

10	Veer	Receiver ground	1	
11	Veer	Receiver ground	1	
12	RX-	Inv. Receiver Data Out	3	Note5
13	RX+	Receiver Data Out	3	Note5
14	VeeR	Receiver ground	1	
15	VccR	Receiver Power Supply	2	
16	VccT	Transmitter Power Supply	2	
17	VeeT	Transmitter Ground	1	
18	TX+	Transmit Data In	3	Note6
18	TX-	Inv. Transmit Data In	3	Note6
20	VeeT	Transmitter Ground	1	

Notes:

Plug Seq. : Pin engagement sequence during hot plugging.

1) TX Fault is an open collector output, which should be pulled up with a 4.7k~10k Ω resistor on the host board to a voltage between 2.0V and Vcc+0.3V. Logic 0 indicates normal operation; logic 1 indicates a laser fault of some kind. In the low state, the output will be pulled to less than 0.8V.

2) TX Disable is an input that is used to shut down the transmitter optical output. It is pulled up within the module with a 4.7 C 10 K resistor.

Its states are:

Low (0 to 0.8V): Transmitter on

(>0.8, < 2.0V): Undefined

The Advanced Networking Technology

High (2.0 to 3.465V): Transmitter Disabled

Open: Transmitter Disabled

3) Mod-Def 0,1,2. These are the module definition pins. They should be pulled up with a 4.7K to 10K resistor on the host board. The pull-up voltage shall be VccT or VccR

Mod-Def 0 is grounded by the module to indicate that the module is present

Mod-Def 1 is the clock line of two wire serial interface for serial ID

Mod-Def 2 is the data line of two wire serial interface for serial ID

4) LOS (Loss of Signal) is an open collector/drain output, which should be pulled up with a 4.7K to 10K resistor. Pull up voltage between 2.0V and VccT, R+0.3V. When high, this output indicates the received optical power is below the worst-case receiver sensitivity (as defined by the standard

+3.3 Volt Electrical PowerInterface						
Parameter	Symbol	Min	Typ	Max	unit	Notes/Conditions
Supply Current	Is		320	375	mA	1.2W max power overfull range of voltageand temperature.See caution note below
Input Voltage	Vcc	3.13	3.3	3.47	V	Referenced to GND
Maximum Voltage	Vmax			4	V	
Surge Current	Isurge			30	mA	Hot plug above steady statecurrent. See caution notebelow

in use). Low indicates normal operation. In the low state, the output will be pulled to <0.8V.

5) RD-/+ : These are the differential receiver outputs. They are AC coupled 100 differential lines which should be terminated with 100 (differential) at the user SERDES.

6) TD-/+ : These are the differential transmitter inputs. They are AC-coupled, differential lines with 100 differential termination inside the module.

5. +3.3V Volt Electrical Power Interface

The module has an input voltage range of +3.3V +/- 5%. The 3.3V maximum voltage is not allowed for continuous operation.

Caution: Power consumption and surge current are higher than the specified values in the SFP MSA

Low-Speed Signals

MOD_DEF(1) (SCL) and MOD_DEF(2) (SDA), are open drain CMOS signals (see section VII, “Serial Communication Protocol”).

Both MOD_DEF(1) and MOD_DEF(2) must be pulled up to host_Vcc.

Low-Speed Signals, Electronic Characteristics					
Parameter	Symbol	Min	Max	unit	Notes/Conditions
SFP Output LOW	VOL	0	0.5	V	4.7k to 10k pull-up to host_Vcc, measured at host side of connector
SFP Output HIGH	VOH	host_Vcc -0.5	host_Vcc + 0.3	V	4.7k to 10k pull-up to host_Vcc, measured at host side of connector
SFP Input LOW	VIL	0	0.8	V	4.7k to 10k pull-up to Vcc, measured at SFP side of connector
SFP Input HIGH	VIH	2	Vcc + 0.3	V	4.7k to 10k pull-up to Vcc, measured at SFP side of connector

High-Speed Electrical Interface

All high-speed signals are AC-coupled internally.

High-Speed Electrical Interface, Transmission Line-SFP						
Parameter	Symbol	Min	Typ	Max	unit	Notes/Conditions
Line Frequency	fL		125		MHz	5-level encoding, per IEEE 802.3
Tx Output Impedance	Zout,TX		100		Ohm	Differential, for all frequencies between 1MHz and 125MHz
Rx Input Impedance	Zin,RX		100		Ohm	Differential, for all frequencies between 1MHz and 125MHz

High-speed electrical interface, host-SFP

High-Speed Electrical Interface, Host-SFP						
Parameter	Symbol	Min	Typ	Max	unit	Notes/Conditions
Single ended data input swing	Vinsing	250		1200	mV	Single ended
Single ended data output swing	Voutsing	350		800	mV	Single ended
Rise/Fall Time	T_r, T_f		175		psec	20%-80%
Tx Input Impedance	Zin		50		Ohm	Single ended
Rx Output Impedance	Zout		50		Ohm	Single ended

General Specifications

General						
Parameter	Symbol	Min	Typ	Max	unit	Notes/Conditions
Data Rate	BR	10		1000	Mb/sec	IEEE 802.3 compatible. See Notes2 through 4 below
Cable Length	L			100	m	Category 5UTP.BER<10-12

Notes:

1. Clock tolerance is +/- 50 ppm
2. By default, the module is a full duplex device in preferred master mode
3. Automatic crossover detection is enabled. External crossover cable is not required
4. RP-MGT1000 support SERDES the module will operate at 1000 BASE-T.
RP-MGT1000A support SGMII the module will operate at 10/100/ 1000 BASE-T.

Environmental Specifications

Environmental Specification						
Parameter	Symbol	Min	Typ	Max	unit	Notes/Conditions
Case Operating Temperature	Tcase	0		70	°C	
Storage Temperature	Tsto	-40		85	°C	Ambient temperature

Mechanical Specifications(Unit:mm)

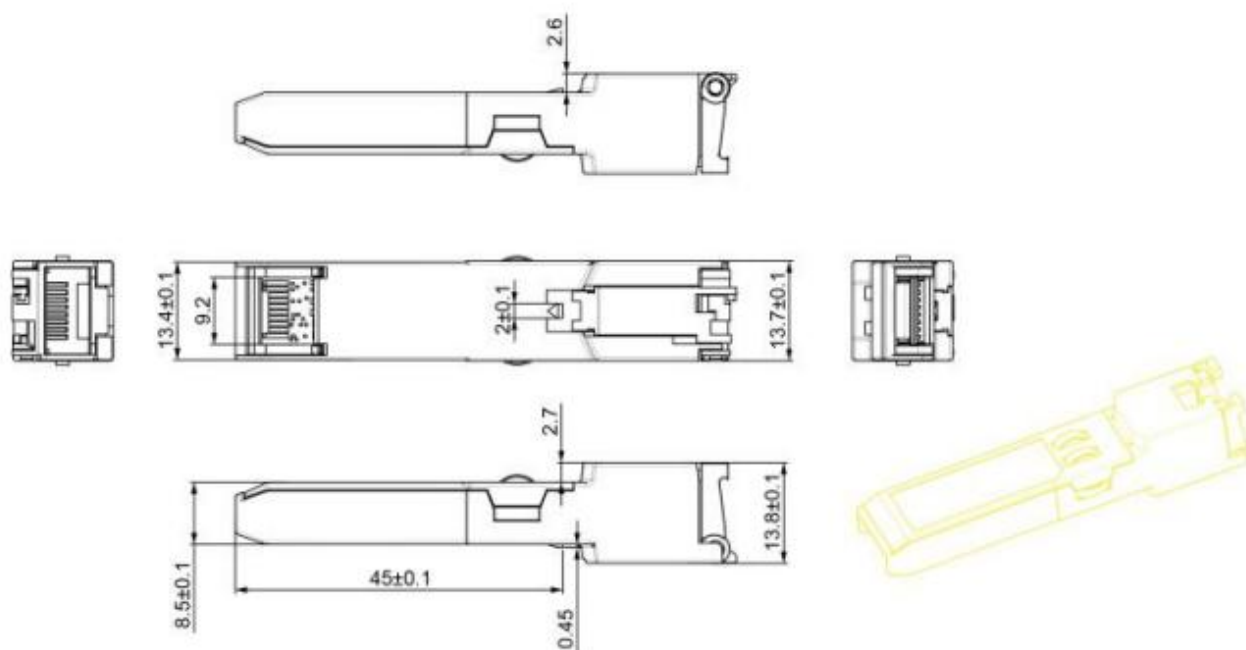

Ordering Information

Part number	Speed mode	MAC interface	TX Disable function	Link Indicator on RX_LOS Pin	Temp.
RP-MGT1000A	10/100/1000Mbps	SGMII	Yes	Yes	0~70°C
RP-MGT1000	1000Mbps	SERDES	Yes	Yes	0~70°C